

<b>Nr.:</b>	714_16_DE Version 00	<b>Gewicht:</b>	ca.7,1 kg	<b>Maßstab:</b>	1 : 10
<b>Titel:</b>	Kleinbauende pneum. Z-Achse, Hub 100 mm mit Markierkopf MV5 U85/45 INTEGRAL, Arbeitsstellung	<b>Maßeinheit:</b>	mm	<b>Erstellt am:</b>	20.05.2021

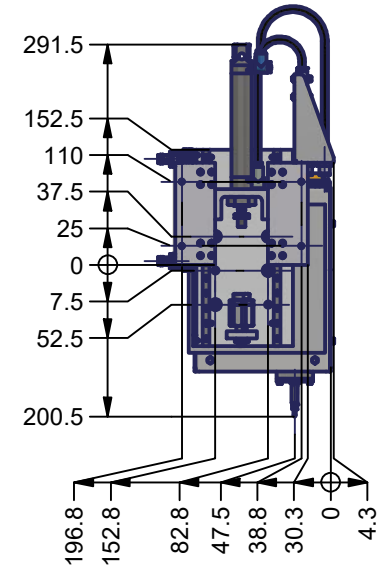

ISO-Ansicht ( 1 : 10 )

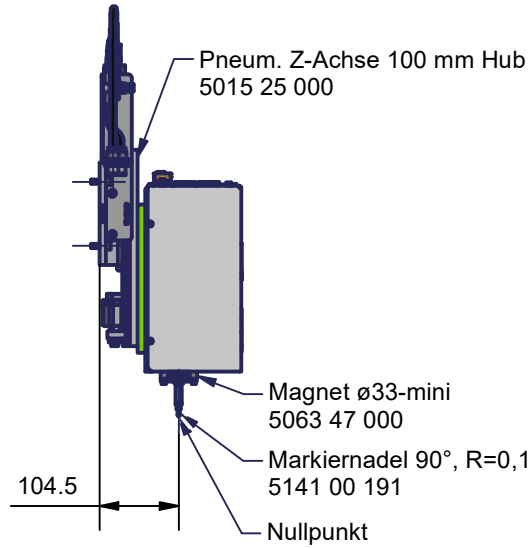
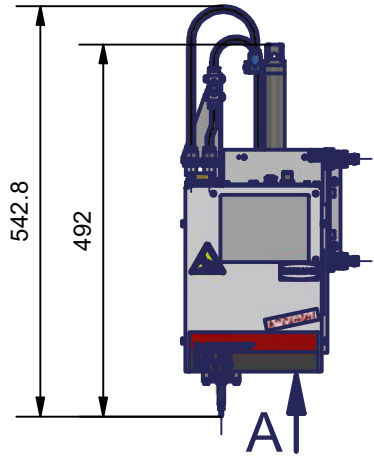
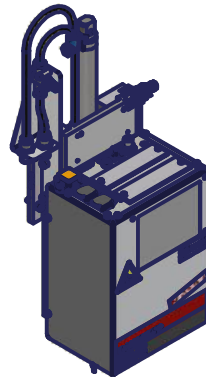
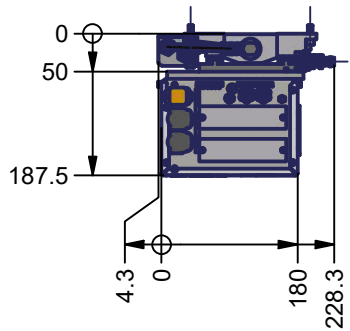

A ( 1 : 10 )

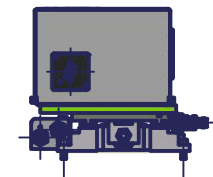

Markierbereich:  
x = 85 mm  
y = 25 mm

Änderungen vorbehalten